

Classic 6½" Midwoofer

Type Number: 18W/8535-00

Features:

The Classic line consists of all the highly regarded transducers that have been appraised and loved by so many customers over the years. The goal has been to assemble all the diamonds, developed over the years, speakers that fully live up to the heritage of the brand.

Driver Highlights: Low loss rubber surround, carbon fibre/paper cone, SD-1 motor



Specs:

Electrical Data

| | | | |
|-----------------------|------|-----|-----|
| Nominal impedance | Zn | 8 | ohm |
| Minimum impedance | Zmin | -- | ohm |
| Maximum impedance | Zo | -- | ohm |
| DC resistance | Re | 5.8 | ohm |
| Voice coil inductance | Le | 0.3 | mH |

T-S Parameters

| | | | |
|-------------------------|-----|------|-----------------|
| Resonance Frequency | fs | 26 | Hz |
| Mechanical Q factor | Qms | 2.5 | |
| Electrical Q factor | Qes | 0.45 | |
| Total Q factor | Qts | 0.38 | |
| Force factor | Bl | 5.7 | Tm |
| Mechanical resistance | Rms | 1 | Kg/s |
| Moving mass | Mms | 15.5 | g |
| Suspension compliance | Cms | -- | mm/N |
| Effective cone diameter | D | -- | cm |
| Effective piston area | Sd | 145 | cm ² |
| Equivalent volume | Vas | 72 | ltrs |
| Sensitivity (2.83V/1m) | | 86.5 | dB |
| Ratio BL/√(Re) | | -- | |
| Ratio fs/Qts | F | -- | |

Power handling

| | | |
|---------------------------------|----|------|
| 100h RMS noise test (IEC) | 70 | W |
| Long-term Max Power (IEC 18.3) | -- | W |
| Max linear SPL (rms) @ power | -- | dB/W |
| Short Term Max power (IEC 18.2) | -- | W |

Voice Coil and Magnet Parameters

| | | |
|-------------------------|----|-----|
| Voice coil diameter | 38 | mm |
| Voice coil height | -- | mm |
| Voice coil layers | -- | |
| Height of the gap | -- | mm |
| Linear excursion +/- | 5 | mm |
| Max mech. excursion +/- | 10 | mm |
| Flux density of gap | -- | mWb |
| Total useful flux | -- | mWb |
| Diameter of magnet | -- | mm |
| Height of magnet | -- | mm |
| Weight of magnet | -- | Kg |

Notes:
IEC specs refer to IEC 60268-5 third edition.
All ScanSpeak products are RoHS compliant.

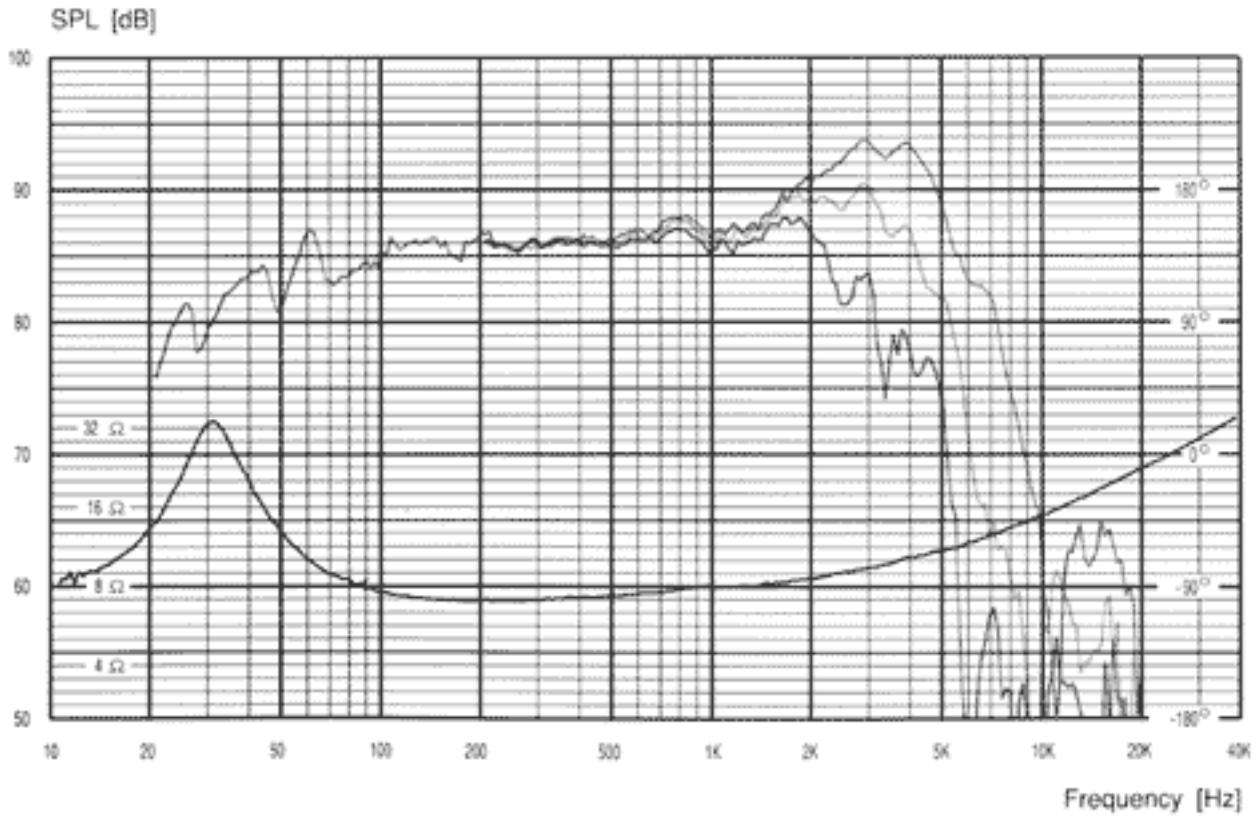

Mechanical Dimensions:18W/8535-00

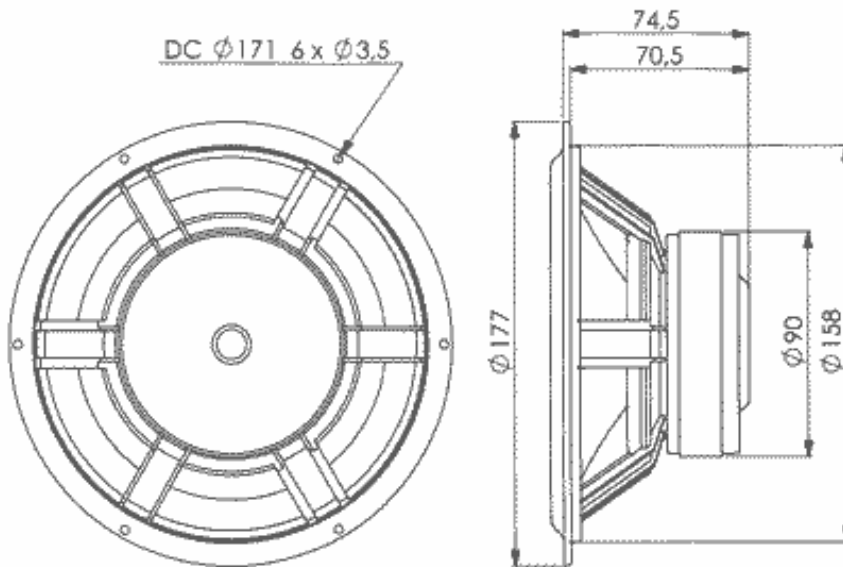

- Drawing Dimensions**
- Outside Diameter
 - Flange Thickness
 - Magnet Diameter
 - Cutout Diameter
 - Interior Depth
 - Hole Diameter
 - Screw Circle Diameter