

HDS PPB 8" Woofer



Type Number: 830868

Features:

The new High Definition Sound (HDS) PPB series is the culmination of Peerless working in close partnership with end users of Peerless-based audio products. With a deep understanding of customer requirements and needs, Peerless developed the proprietary and highly advanced Polypropylene Black (PPB) cone material used in the HDS PPB Series, creating a stiff but still dampened cone that remains stable even under the greatest sound pressures.

See architecture notes for [HDS Platform](#)

Discontinued. Replaced by 831868.

Driver Highlights: PPM diaphragm, 33 mm coil, AL

See [Application Notes](#)

[Go to Application Notes.](#)

[Go to Architecture Notes](#)



Specs:

Electrical Data

Nominal impedance	Zn	8	ohm
Minimum impedance	Zmin	6.1	ohm
Maximum impedance	Zo	57.2	ohm
DC resistance	Re	5.5	ohm
Voice coil inductance	Le	1.5	mH

T-S Parameters

Resonance Frequency	fs	32.5	Hz
Mechanical Q factor	Qms	4.09	
Electrical Q factor	Qes	0.44	
Total Q factor	Qts	0.4	
Force factor	Bl	8.1	Tm
Mechanical resistance	Rms	1.28	Kg/s
Moving mass	Mms	25.6	g
Suspension compliance	Cms	0.94	mm/N
Effective cone diameter	D	16.8	cm
Effective piston area	Sd	221	cm ²
Equivalent volume	Vas	63.4	ltrs
Sensitivity (2.83V/1m)		90.1	dB
Ratio BL/√(Re)		3.5	
Ratio fs/Qts	F	82	

Power handling

100h RMS noise test (IEC)	--	W
Long-term Max Power (IEC 18.3)	--	W
Max linear SPL (rms) @ power	--	dB/W
Short Term Max power (IEC 18.2)	--	W

Voice Coil and Magnet Parameters

Voice coil diameter	33	mm
Voice coil height	17	mm
Voice coil layers	4	
Height of the gap	6	mm
Linear excursion +/-	5.5	mm
Max mech. excursion +/-	--	mm
Flux density of gap	--	mWb
Total useful flux	--	mWb
Diameter of magnet	102	mm
Height of magnet	20	mm
Weight of magnet	0.68	Kg

Notes:
IEC specs refer to IEC 60268-5 third edition.
All Tympany products are RoHS compliant.

Frequency: 830868

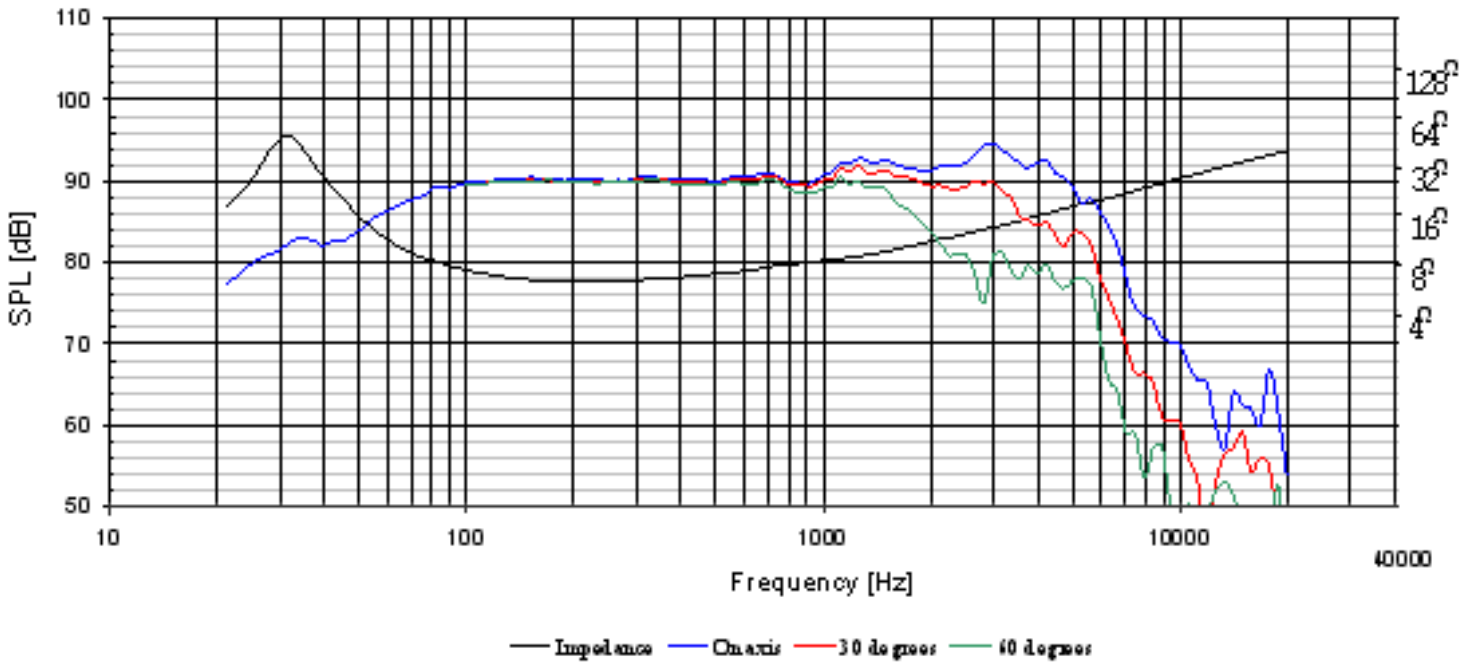

Mechanical Dimensions:830868

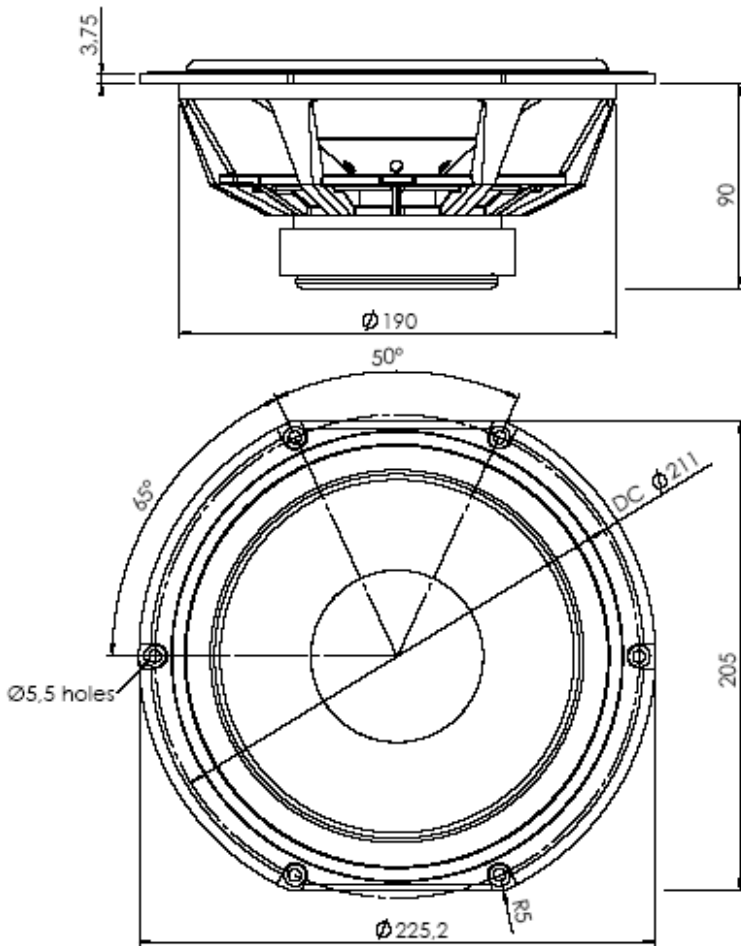

Drawing Dimensions

- Outside Diameter
- Flange Thickness
- Magnet Diameter
- Cutout Diameter
- Interior Depth
- Hole Diameter
- Screw Circle Diameter