

## D 1" Tweeter

Type Number: D26NC-55-06

### Features:

Driver Highlights: 1" dome compact tweeter, fabric diaphragm, ferrofluid, double chamber, neodymium magnet, magnetically shielded



### Specs:

#### Electrical Data

Nominal impedance	Zn	6	ohm
Minimum impedance	Zmin	--	ohm
Maximum impedance	Zo	--	ohm
DC resistance	Re	4.6	ohm
Voice coil inductance	Le	0.05	mH

#### T-S Parameters

Resonance Frequency	fs	1390	Hz
Mechanical Q factor	Qms	2.09	
Electrical Q factor	Qes	3.67	
Total Q factor	Qts	1.33	
Force factor	Bl	1.85	Tm
Mechanical resistance	Rms	--	Kg/s
Moving mass	Mms	0.31	g
Suspension compliance	Cms	--	mm/N
Effective cone diameter	D	--	cm
Effective piston area	Sd	7.1	cm <sup>2</sup>
Equivalent volume	Vas	0.002	ltrs
Sensitivity (2.83V/1m)		91	dB

#### Power handling

Long-term Max Power (IEC 18.3)	100	W
Short Term Max power (IEC 18.2)	400	W

#### Voice Coil and Magnet Parameters

Voice coil diameter	25	mm
Voice coil height	1.5	mm
Voice coil layers	--	
Height of the gap	2	mm
Flux density of gap	--	mWb
Total useful flux	--	mWb
Diameter of magnet	--	mm
Height of magnet	--	mm
Weight of magnet	0.011	Kg

Notes:  
IEC specs refer to IEC 60268-5 third edition.  
All Tymphany products are RoHS compliant.

Frequency: D26NC-55-06

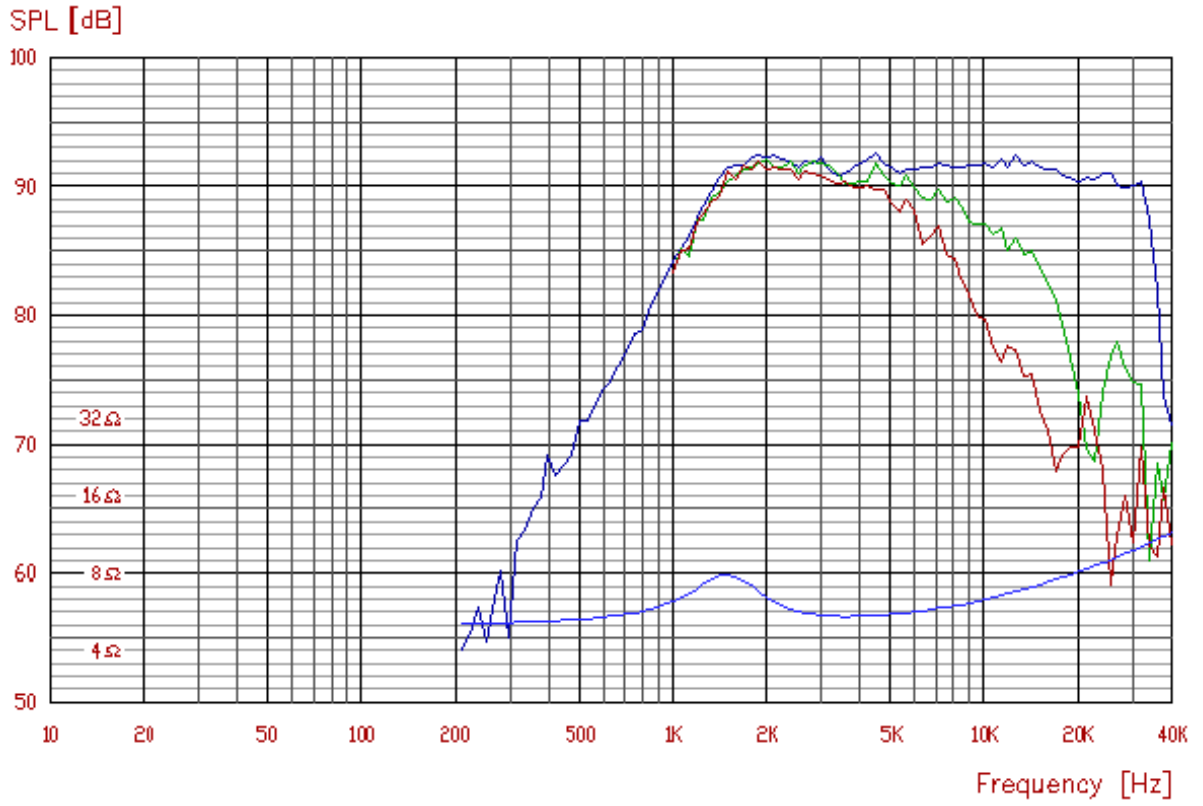

Mechanical Dimensions: D26NC-55-06

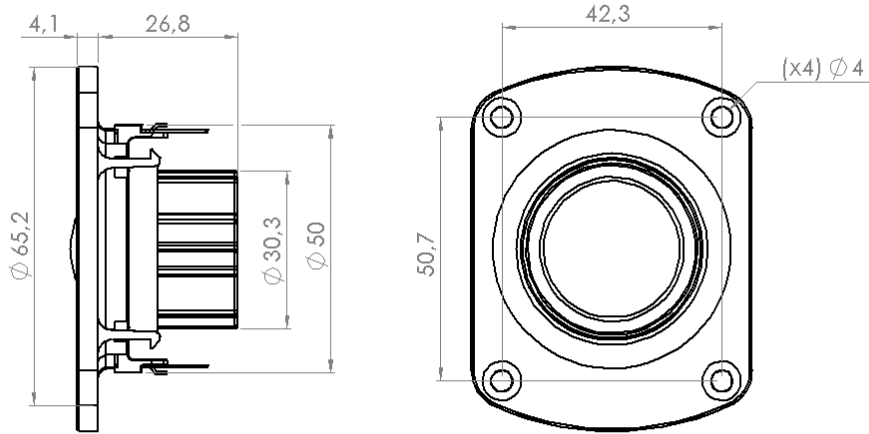

D26NC-55-06