

Classic 1½" Tweeter

Type Number: D3806/820000

Features:

The Classic line consists of all the highly regarded transducers that have been appraised and loved by so many customers over the years. The goal has been to assemble all the diamonds, developed over the years, speakers that fully live up to the heritage of the brand.

Driver Highlights: 1½" upper midrange, soft dome, SD motor, rear chamber



Specs:

Electrical Data

Nominal impedance	Zn	6	ohm
Minimum impedance	Zmin	--	ohm
Maximum impedance	Zo	--	ohm
DC resistance	Re	5.7	ohm
Voice coil inductance	Le	0.04	mH

T-S Parameters

Resonance Frequency	fs	450	Hz
Mechanical Q factor	Qms	--	
Electrical Q factor	Qes	--	
Total Q factor	Qts	--	
Force factor	Bl	3.8	Tm
Mechanical resistance	Rms	--	Kg/s
Moving mass	Mms	0.9	g
Suspension compliance	Cms	--	mm/N
Effective cone diameter	D	--	cm
Effective piston area	Sd	14	cm ²
Equivalent volume	Vas	--	ltrs
Sensitivity (2.83V/1m)		89	dB

Power handling

100h RMS noise test (IEC)	100	W
Long-term Max Power (IEC 18.3)	--	W
Short Term Max power (IEC 18.2)	--	W

Voice Coil and Magnet Parameters

Voice coil diameter	38	mm
Voice coil height	--	mm
Voice coil layers	--	
Height of the gap	--	mm
Linear excursion +/-	0.4	mm
Max mech. excursion +/-	1	mm
Flux density of gap	--	mWb
Total useful flux	--	mWb
Diameter of magnet	--	mm
Height of magnet	--	mm
Weight of magnet	--	Kg

Notes:
IEC specs refer to IEC 60268-5 third edition.
All ScanSpeak products are RoHS compliant.

Frequency: D3806/820000

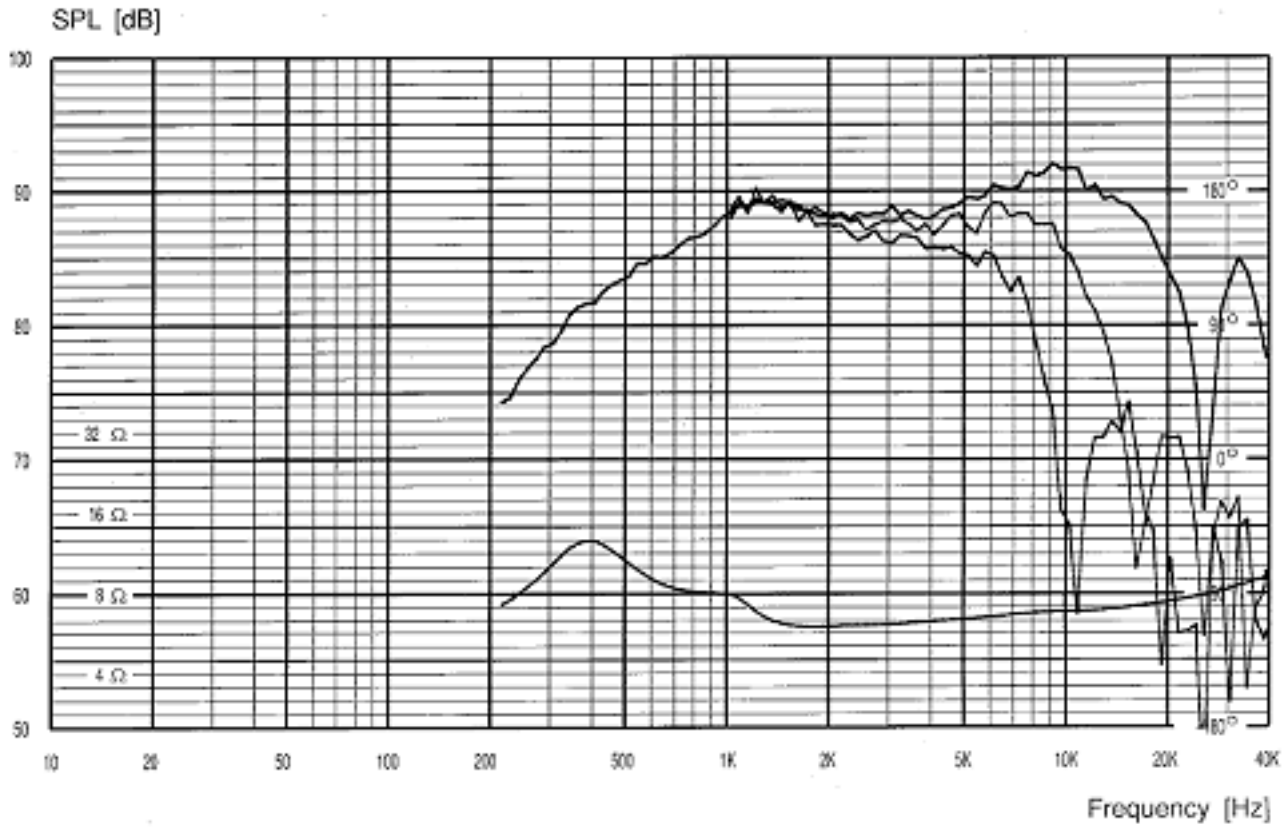

Mechanical Dimensions: D3806/820000

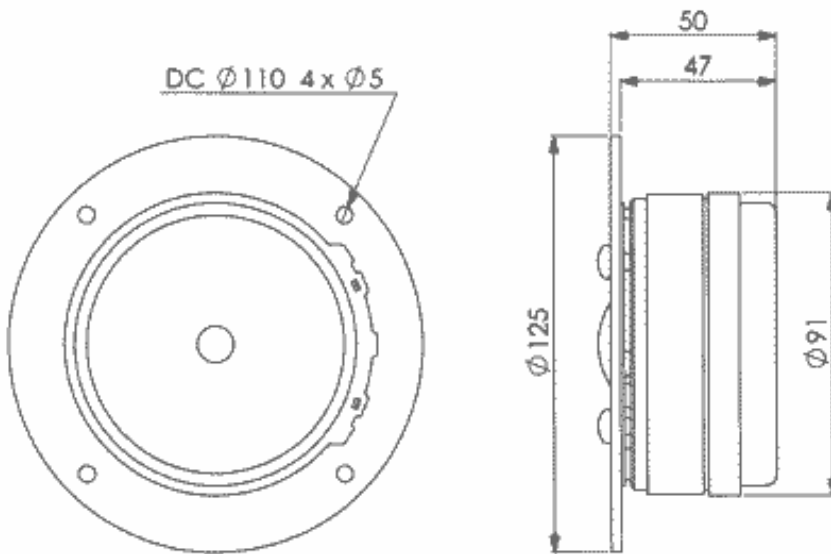

- Drawing Dimensions**
- Outside Diameter
 - Flange Thickness
 - Magnet Diameter
 - Cutout Diameter
 - Interior Depth
 - Hole Diameter
 - Screw Circle Diameter