

5¼" Midwoofer

Type Number: MG14SK09-04

Features:

Driver Highlights: 5½" midwoofer, glass fibre cone, magnesium chassis, magnetically shielded



Specs:

Electrical Data

Nominal impedance	Zn	4	ohm
Minimum impedance	Zmin	--	ohm
Maximum impedance	Zo	--	ohm
DC resistance	Re	3	ohm
Voice coil inductance	Le	0.45	mH

T-S Parameters

Resonance Frequency	fs	43	Hz
Mechanical Q factor	Qms	1.95	
Electrical Q factor	Qes	0.27	
Total Q factor	Qts	0.24	
Force factor	Bl	5.2	Tm
Mechanical resistance	Rms	--	Kg/s
Moving mass	Mms	9	g
Suspension compliance	Cms	--	mm/N
Effective cone diameter	D	--	cm
Effective piston area	Sd	80	cm ²
Equivalent volume	Vas	13.2	ltrs
Sensitivity (2.83V/1m)		90	dB
Ratio BL/√(Re)		--	
Ratio fs/Qts	F	--	

Power handling

100h RMS noise test (IEC)	--	W
Long-term Max Power (IEC 18.3)	--	W
Max linear SPL (rms) @ power	--	dB/W
Short Term Max power (IEC 18.2)	--	W

Voice Coil and Magnet Parameters

Voice coil diameter	25	mm
Voice coil height	12	mm
Voice coil layers	--	
Height of the gap	5	mm
Linear excursion +/-	--	mm
Max mech. excursion +/-	--	mm
Flux density of gap	--	mWb
Total useful flux	--	mWb
Diameter of magnet	--	mm
Height of magnet	--	mm
Weight of magnet	--	Kg

Notes:
IEC specs refer to IEC 60268-5 third edition.
All Tymphany products are RoHS compliant.

Frequency:

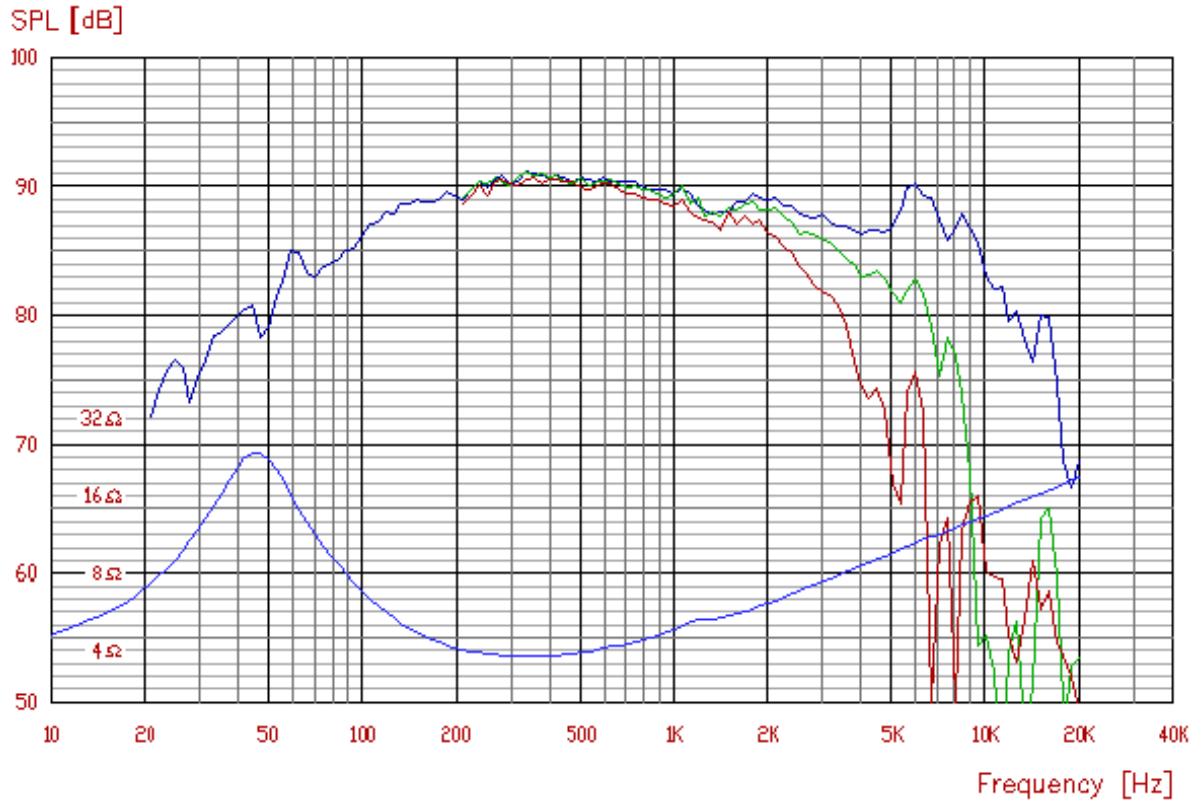

Mechanical Dimensions:

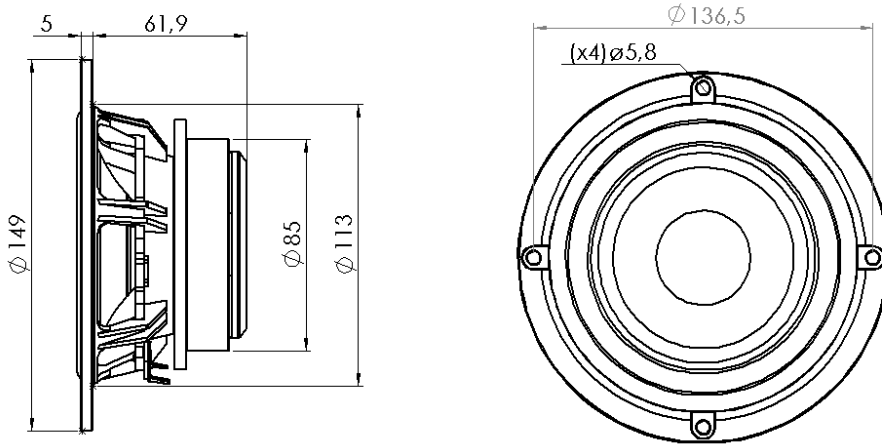

MG14SK09-04
MG14SK09-08