

XT/DX 6½" Midwoofer



Type Number: XT18WO09-08

Features:

This series builds on the foundation of the PL series, but with new approaches to further enhance the performance. With a high density, low resonance, airflow-optimized chassis it allows maximum airflow under the spider. The result is much lower compression of air in the magnet system, which has also been optimized to reduce distortion. A Wood-fibre cone and phase integrated dust cap is a new technology that strives for the optimum sound quality. Vifa has always been known for searching for the best sound and will only adapt the best materials to achieve this. Low Resonance Multi-roll Surround (LRMS) is another design element used in this series to reduce resonance.

Driver Highlights: Wood-fibre cone and dustcap, Multi-roll surround, low distortion magnet system, airflow optimized chassis



Specs:

Electrical Data

Nominal impedance	Zn	8	ohm
Minimum impedance	Zmin	--	ohm
Maximum impedance	Zo	85	ohm
DC resistance	Re	5.8	ohm
Voice coil inductance	Le	0.54	mH

T-S Parameters

Resonance Frequency	fs	38	Hz
Mechanical Q factor	Qms	5.87	
Electrical Q factor	Qes	0.39	
Total Q factor	Qts	0.37	
Force factor	Bl	6.2	Tm
Mechanical resistance	Rms	0.49	Kg/s
Moving mass	Mms	11.1	g
Suspension compliance	Cms	--	mm/N
Effective cone diameter	D	--	cm
Effective piston area	Sd	129	cm ²
Equivalent volume	Vas	38	ltrs
Sensitivity (2.83V/1m)		88	dB
Ratio BL/√(Re)		--	
Ratio fs/Qts	F	--	

Power handling

100h RMS noise test (IEC)	--	W
Long-term Max Power (IEC 18.3)	--	W
Max linear SPL (rms) @ power	--	dB/W
Short Term Max power (IEC 18.2)	--	W

Voice Coil and Magnet Parameters

Voice coil diameter	25	mm
Voice coil height	14	mm
Voice coil layers	--	
Height of the gap	5	mm
Linear excursion +/-	--	mm
Max mech. excursion +/-	--	mm
Flux density of gap	--	mWb
Total useful flux	--	mWb
Diameter of magnet	--	mm
Height of magnet	--	mm
Weight of magnet	--	Kg

Notes:
IEC specs refer to IEC 60268-5 third edition.
All Tymphany products are RoHS compliant.

Frequency:

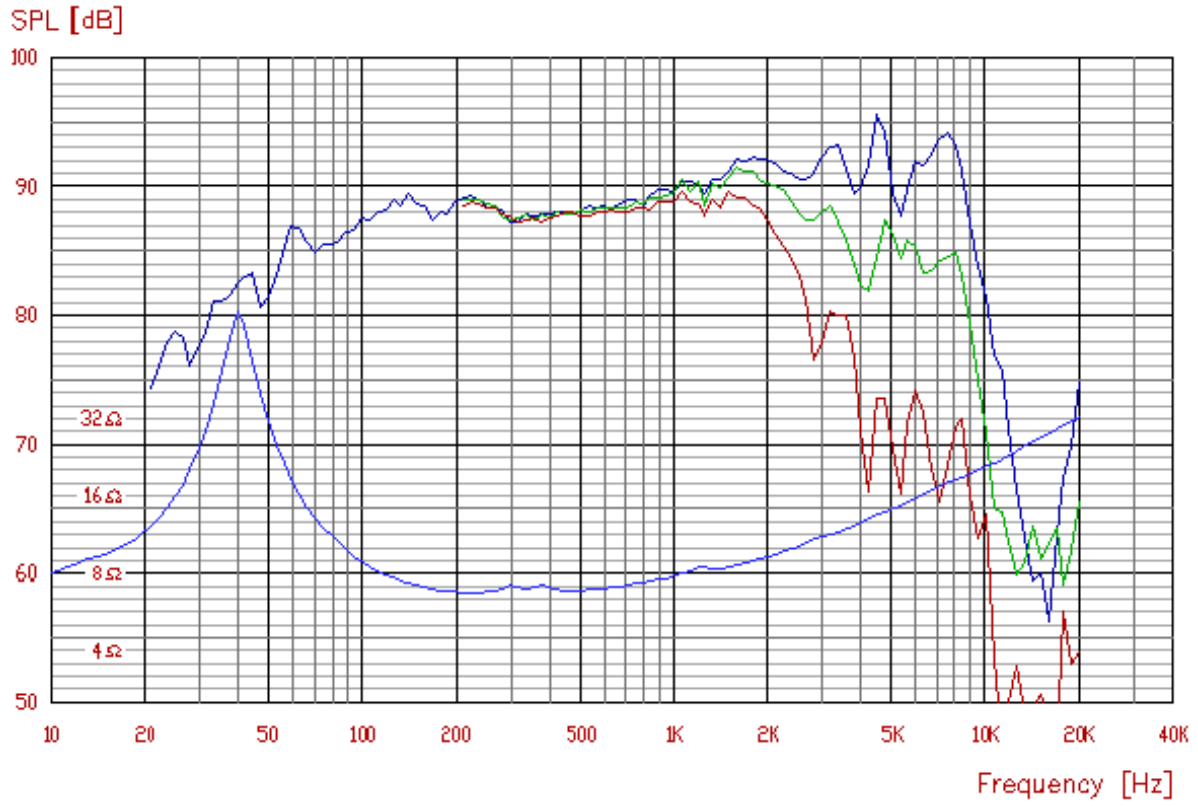

Mechanical Dimensions:

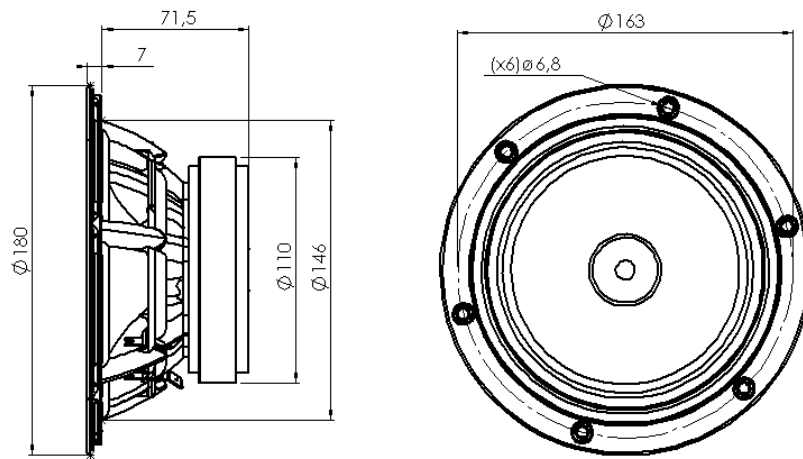

XT18WO09-08